

Layout Guidelines



1. Introduction

Open circuit cooling towers, closed circuit cooling towers and evaporative condensers all depend upon an adequate supply of fresh, ambient air to provide design capacity. Other important considerations such as the proximity to building air intakes or discharges also must be taken into account when selecting and designing the equipment site. Included are the design layout guidelines for evaporative cooling products in several situations typically encountered by designers. These guidelines represent **minimum recommended spacing requirements**; more open spacing should be utilized whenever possible.

As the size of an installation increases, the total amount of heat being rejected to the atmosphere and the volume of discharge air increase - to the point where the units can virtually create their own environment. As a result, it becomes increasingly difficult to apply a set of general guidelines for each case. Such installations, and particularly those in wells or enclosures, will recirculate and the problem becomes one of controlling the amount of recirculation and/or adjusting the design wet-bulb temperature to allow for it. Consequently, any job that involves four or more cells should be referred to your local BAC Balticare Representative for review.

2. Location

Each unit should be located and positioned to prevent the introduction of the warm discharge air and the associated drift, which may contain chemical or biological contaminants including Legionella, into the ventilation systems of the building on which the unit is located or those of adjacent buildings.

For detailed recommendations on layout, please consult your local BAC Balticare Representative.

For forced draught counterflow products, bottom screens or solid bottom panels may be desirable or necessary for safety, depending on the location and conditions at the installation site.

3. General Considerations

When selecting the site for a cooling tower, closed circuit cooling tower, an evaporative condenser or a water saving hybrid wet/dry product, consider the following factors:

- ♦ Locate the unit to prevent the warm discharge air from being introduced into the fresh air intakes of the building(s) served by the unit, intakes of neighbouring buildings, or from being carried over any populated area such as a building entrance.

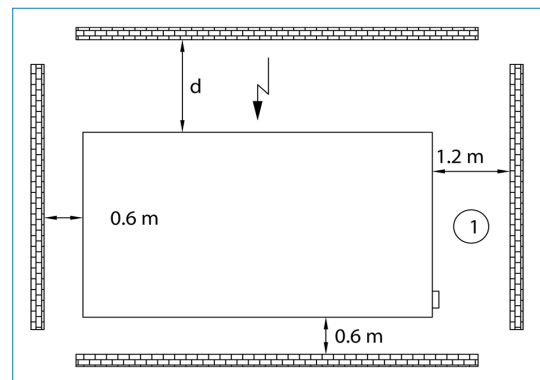

Figure 1: Plan view for single air inlet unit
1. Connection end

- ◆ Consider the potential for plume formation and its effect on the surroundings, such as large windowed areas, and pedestrian or vehicular traffic arteries, particularly if the unit(s) will be operated during low ambient temperatures.
- ◆ Provide sufficient unobstructed space around the unit(s) to ensure an adequate supply of fresh, ambient air to the air intake. Avoid situations that promote recirculation of unit discharge air, such as units located:
 - a. Adjacent to walls or structures that might deflect some of the discharge air stream back into the air intake.
 - b. Where high downward air velocities in the vicinity of the air intake exist.
 - c. Where building air intakes or exhausts, such as boiler stacks in the vicinity of the unit, might raise the inlet wet-bulb temperature or starve the unit of air.
- ◆ Provide adequate space around the unit for piping and proper servicing and maintenance, as shown in the figures.

Besides the layout situation, a distinction can be made between different unit configurations:

- ◆ unit with only one air intake side
- ◆ units with two air intake sides
- ◆ units having air intakes on all four sides

For forced draught counterflow units the connection end is situated at the opposite end of the air intake.

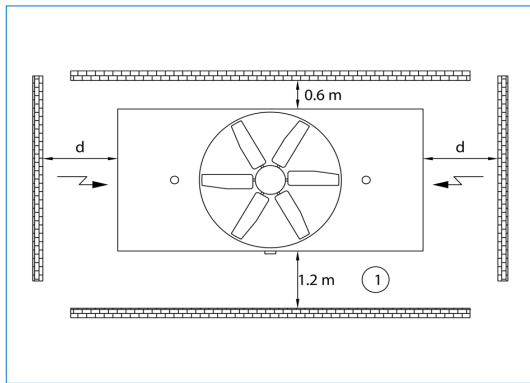

Figure 2: Plan View for dual air inlet unit
1. Connection End.

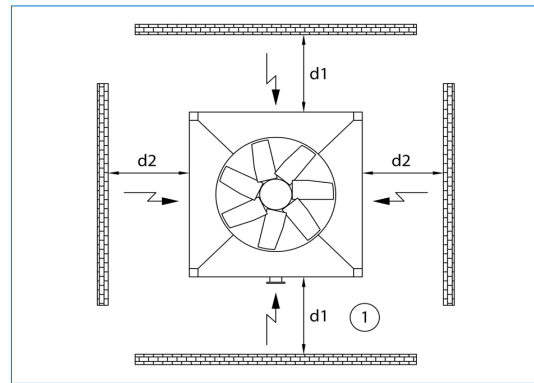

Figure 3: Plan View for four air inlet unit
1. Connection End.

- ◆ The top of the fan discharge cylinder, velocity recovery stack, or discharge sound attenuation must be at least level with, and preferably higher than any adjacent walls or buildings.
- ◆ When possible, orient the unit so the prevailing summer wind blows the discharge air away from the air intakes of the unit(s).
- ◆ When the unit is installed with intake sound attenuation, the distances should be measured from the face of the intake sound attenuation.
- ◆ On larger unit installations, the problem of ensuring an adequate supply of fresh, ambient air to the tower intake becomes increasingly difficult. See the “Multi Unit Installation” section of this article for specific considerations.
- ◆ If the installation does not meet the recommended guidelines, the units will have a greater tendency to recirculate and the design conditions should be altered to include an allowance for the recirculation. For instance, if the design conditions are 32 / 27 / 21°C and it was estimated that the allowance for recirculation rate was 1 °C, then the new design conditions would be 32 / 27 / 22°C and the units should be reselected based on the new design conditions.

The “Layout Guidelines” describe several typical site layouts for BAC’s cooling towers, closed circuit cooling towers, water saving hybrid wet-dry products and evaporative condensers.

In most cases, the site layout can be categorised according to one of the following situations:

- ◆ Adjacent to a building or wall
- ◆ Well installation
- ◆ Louvered well installation
- ◆ Multi unit installation
- ◆ Indoor installation
- ◆ Dry Coolers and Dry Coolers with Adiabatic Pre-Cooling

If these guidelines do not cover a particular situation or if the layout criteria cannot be met, please refer the application to your BAC Baltimore Representative for review. Please indicate prevailing wind direction, geographic orientation of the unit(s), and other factors such as large buildings and other obstructions that may influence layout decisions.

4. Adjacent to a Building or a Wall

General

- ◆ **Unit Orientation:**
When a unit is located near a building wall, the referred arrangement is to have the unit situated with the cased end or blank-off side (unlouvered side) facing the adjacent wall or building.
- ◆ **Air Inlet Requirements:**
Should it be necessary to install a unit with the air intake facing a wall, provide at least distance “d” between the air intake and the wall, as illustrated in the figures that follow (see “Examples”).

Below is the method for determining the minimum acceptable dimension “d” for a unit located with the air intake facing a solid wall:

The maximum acceptable envelope air velocity for all products - except centrifugal fan units with tapered hood - is 1,5 m/s, as illustrated in the following equation:

$$\text{Envelope Velocity} = \frac{\text{Unit Airflow}}{\text{Envelope Area}} < 1,5 \text{ m/s}$$

For centrifugal fan units with a tapered hood the maximum acceptable air velocity increases to 2 m/s as illustrated in the following equation:

$$\text{Envelope Velocity} = \frac{\text{Unit Airflow}}{\text{Envelope Area}} < 2 \text{ m/s}$$

The envelope area is illustrated in the figures that follow hereafter (see “Examples”):

$[(L+0,6+0,6) \times d] + 2(H+h) \times d$, where:

- ◆ “H” = height of the air intake face in meter
- ◆ “h” = elevation of the unit from the roof/ground/pad in meter. The maximum elevation is 1,2 meter
- ◆ “L” = length of the air intake in meter
- ◆ “d” = minimum acceptable distance between the wall and the air intake face in meter

Example: VXT-1200 adjacent to a solid wall

What is the minimum distance required between the air inlet of the VXT-1200 when installed facing a wall?

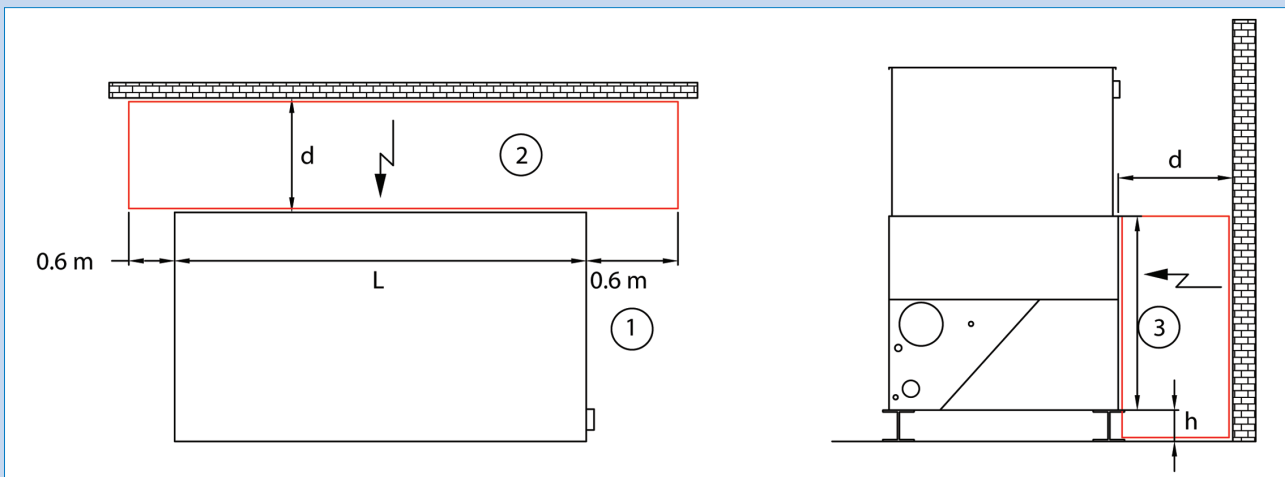

Figure 4: Unit with Single Air Inlet adjacent to a Wall
1. Connection End; 2. Envelope Area; 3. Air Intake Height

Unit Airflow = 109,87 m³/s

H intake = 2,54 m

h = 0 m

0,60 + L + 0,60 = 12,10 m

1,5 m/s = maximum acceptable envelope air velocity with no hood

Envelope Velocity = Unit Airflow / Envelope Area

Solving for “d”:

$$d = \frac{\text{Unit Airflow}}{1,5 [2(H+h)+(L+1,2)]}$$

$$d = \frac{109,87}{1,5 \times [2(2,54+0)+(10,9+1,2)]}$$

$$d = 4,3 \text{ m}$$

Therefore, the air intake should be no less than 4,3 meter from the wall.

Example: S3-D1301-L adjacent to a solid wall

What is the minimum distance required between the air inlet of a single cell S3-D1301-L when installed facing a wall?

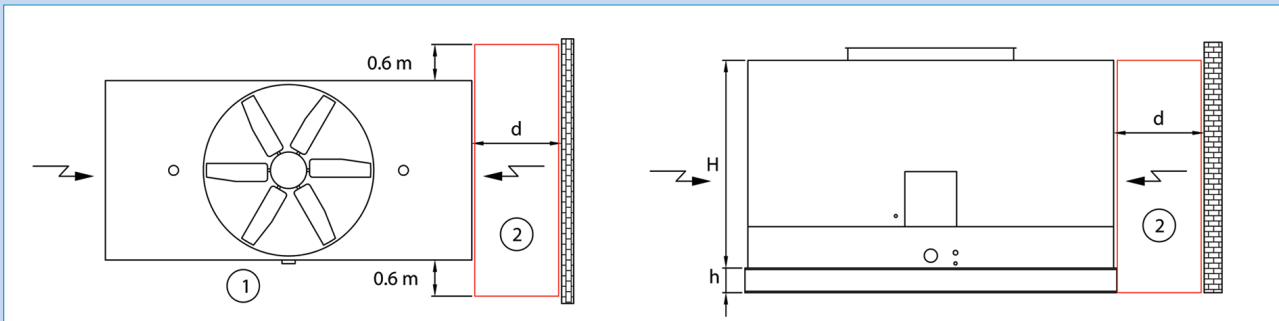

Figure 5: Unit with two Air Inlets adjacent to a Wall
1. Connection End; 2. Envelope Area

Unit Airflow = 138 m³/s
 H = 6,77 m
 h = 0 m
 L = 4,25 m
 1,5 m/s = maximum acceptable envelope air velocity for a cooling tower

Envelope Velocity = Unit Airflow / Envelope Area

$$1,5 \text{ m/s} = \frac{138 \text{ m}^3/\text{s} / 2 \text{ air intake sides}}{[(0,60+4,25+0,60) \times d] + [2(6,77+0) \times d]}$$

$$d \times 18,99 \text{ m} = \frac{69 \text{ m}^3/\text{s}}{1,5 \text{ m/s}}$$

$$d = \frac{69 \text{ m}^3/\text{s} / 1,5 \text{ m/s}}{18,99 \text{ m}}$$

$$d = 2,42 \text{ m}$$

This is rounded up to the next 0,1 m increment. Therefore, the air intake should be located no less than 2,5 meter from the solid wall.

Example: PTE 0812A-3N-L1 adjacent to a solid wall

Below is the method for determining the minimum acceptable dimension “d” for a PTE located adjacent to one or more solid wall(s). The recommended envelope air velocity for a PTE Cooling Tower is 1,5 m/s. We must solve the following equations for the desired distance, “d”:

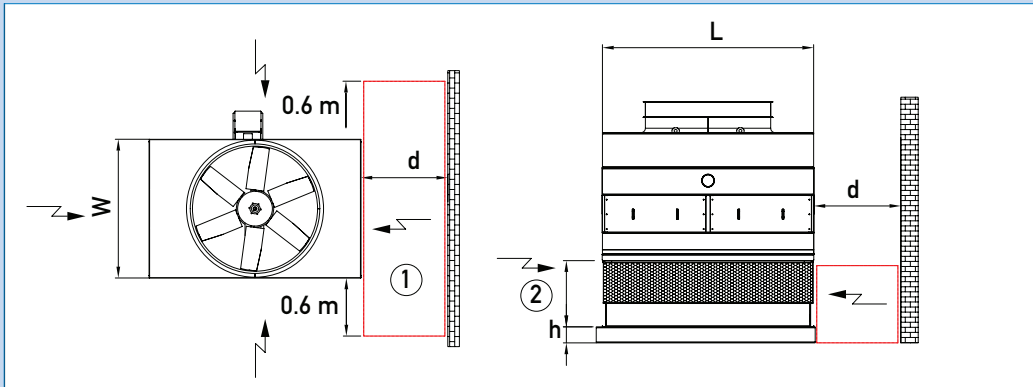

Figure 6: Unit with Four Air Inlets adjacent to a Wall
1. Envelope Area; 2. Air Intake Height

Envelope Air Velocity = % Airflow per Inlet / Envelope Area
 % Airflow per Inlet = L (or W) / Total Air Inlet Perimeter
 Total Air Inlet Perimeter = 2L + 2W

Envelope Area = [(L x d) + 2(A x d)] or [(W x d) + 2(A x d)], where:

- ♦ “A” = height air intake section
- ♦ “L” = length in meter
- ♦ “W” = width in meter
- ♦ “d” = minimum acceptable distance between the wall and the air intake face

What is the minimum distance required between the air inlet of an PTE 0812A-3N-L1 with air inlet face “L” when installed facing a wall? Find minimum acceptable distance “d”.

Unit Airflow = 31,7 m³/s
 A = 0,99 m
 L = 3,60 m
 W = 2,40 m
 Total Air Inlet Perimeter = 2L + 2W = 12 m
 1,5 m/s = suggested envelope air velocity for a cooling tower

Envelope Velocity = Airflow per Inlet / Envelope Area
 % Airflow to Inlet = W / Total Air Inlet Perimeter = 2,40 / 12 = 20%

$$1,5 \text{ m/s} = \frac{31,7 \text{ m}^3/\text{s} \times 20\%}{(2,40 \times d) + 2(0,99 \times d)}$$

Solve for “d” to find the distance from the “L” side of the unit to the wall:

$$d \times 4,38 \text{ m} = \frac{6,34 \text{ m}^3/\text{s}}{1,5 \text{ m/s}}$$

$$d \times 4,38 \text{ m} = \frac{6,34 \text{ m}^3/\text{s} / 1,5 \text{ m/s}}{4,38 \text{ m}}$$

$$d = 0,96 \text{ m}$$

This is rounded up to the next 0,1 m increment. Therefore, the air intake should be located no less than 1 meter from the solid wall.

5. Well Installation

General

The following method is used to determine the minimum acceptable dimension “d” for units installed in a well layout.

The maximum allowable downward air velocity for a well installation is 2 m/s. The downward velocity is determined using the following equation:

$$\text{Downward Air Velocity} = \frac{\text{Unit Airflow}}{\text{Usable Well Area}} < 2 \text{ m/s}$$

Note: The lower face airflow for the combined flow units is 70% of the total unit airflow. The remaining 30% of the airflow enters the unit through the top of the coil section.

The useable well area at each air intake face is defined as illustrated in the figures that follow hereafter (refer to the section “Examples”).

Useable Well Area = [(d)(1,2m+L+1,2m)] + [(1,2m x 0,3m) + (1,2m x 0,3m)], where:

- ◆ “d” = minimum acceptable distance between the air intake of the unit and the wall of the well in meter.
- ◆ “L” = length of the air intake of the unit in meter.

Example 1a: Model VXI-144-3 in a Well Enclosure

If the VXI-144-3 has a tapered discharge hood, what is the minimum distance between the air inlet of the VXI-144-3 in a well?

Unit Airflow = 40,2 m³/s

Length = 3,5 m

2 m/s = maximum allowable downward velocity for a VXI with tapered hood

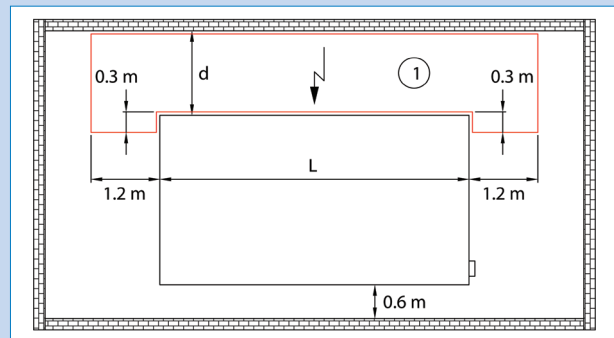

Figure 7: Unit with Single Air Inlet in a Well Enclosure
1. Useable Well Area.

$$2 \text{ m/s} = \frac{40,2 \text{ m}^3/\text{s}}{(d (1,2 \text{ m} + 3,55 \text{ m} + 1,2 \text{ m})) + 2 \times (1,2 \text{ m} \times 0,3 \text{ m})}$$

$$d \times 5,95 \text{ m} + 0,72 \text{ m}^2 = \frac{40,2 \text{ m}^3/\text{s}}{2 \text{ m/s}}$$

$$d = \frac{(40,2 \text{ m}^3/\text{s} / 2 \text{ m/s}) - 0,72 \text{ m}^2}{5,95 \text{ m}}$$

$$d = 3,26 \text{ m}$$

This is rounded up to the next 0,1 m increment. Therefore the air intake should be no less than 3,3 meter from the enclosure walls.

Example 1b: Model FXV-443-M in a Well Enclosure

Unit Airflow = 31,9 m³/s
 L= 3,69 m
 2 m/s = maximum allowable air downward velocity for a cooling tower
 Downward Air Velocity = Louver Face Airflow / Useable Well Area

Solving for “d”:

$$2 \text{ m/s} = \frac{31,9 \text{ m}^3/\text{s} \times 70\%}{(d)(1,2 + 3,69 + 1,2) + 2 \times (1,2 \times 0,3)}$$

$$d \times 6,09 \text{ m} + 0,72 \text{ m}^2 = \frac{22,33 \text{ m}^3/\text{s}}{2 \text{ m/s}}$$

$$d = \frac{(22,33 \text{ m}^3/\text{s} / 2 \text{ m/s}) - 0,72 \text{ m}^2}{6,09 \text{ m}}$$

d = 1,72 m

This is rounded up to the next 0,1 m increment. Therefore, the air intake should be no less than 1,8 meter from the enclosure walls.

Example: Model S3-D1056-2L in a Well

Unit Airflow = 110,6 m³/s x 2 cells = 221,2 m³/s
 L= 2 x 3,60 m = 7,20 m
 2 m/s = maximum allowable air downward velocity for a cooling tower
 Downward Air Velocity = Unit Airflow / Useable Well Area

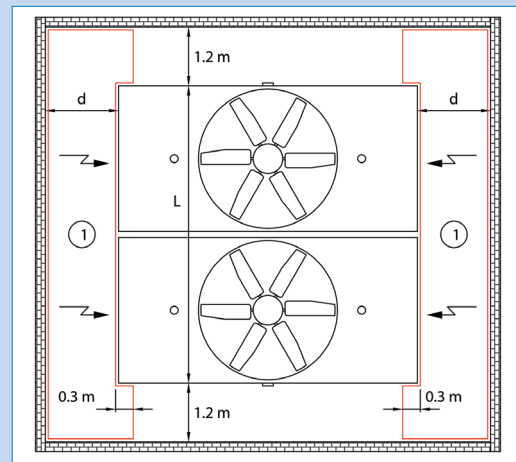

Figure 8: Unit with Two Air Inlets in a Well Enclosure
 1. Useable Well Area

Solving for “d”:

$$2 \text{ m/s} = \frac{221,2 \text{ m}^3/\text{s} \times 2 \text{ air intake sides}}{(d)(1,2 + 7,2 + 1,2) + 2 \times (1,2 \times 0,3)}$$

$$d \times 9,6 \text{ m} + 0,72 \text{ m}^2 = \frac{110,6 \text{ m}^3/\text{s}}{2 \text{ m/s}}$$

$$d = \frac{(110,6 \text{ m}^3/\text{s} / 2 \text{ m/s}) - 0,72 \text{ m}^2}{9,6 \text{ m}}$$

d = 5,68 m

This is rounded up to the next 0,1 m increment. Therefore, the air intakes should be no less than 5,7 meter from the enclosure walls.

6. Louvered Well Installation

General

Check to see if the layout meets the requirements for a well installation. If the criteria for the well installation are met, the layout is satisfactory. If the layout does not satisfy the criteria for the well installation, analyze the layout as follows:

◆ **Air intake requirements:**

Units should be arranged within the enclosure such that:

- a. The air intake directly faces the louver or slot locations as shown in the following figures (see “Examples”).
- b. Maintain a distance of at least 0,9 m between the unit air intake(s) and the louvered or slotted wall for uniform air distribution.

◆ **Louver Requirements:**

- a. Louvers must provide at least 50% net free area to ensure that the unit airflow is not reduced due to friction or dynamic losses and that sufficient air is drawn through the openings and not downward from above.
- b. The required total louver or slot area is based on drawing the total unit airflow through the net free area of the louvers at a velocity of 3 m/s or less.
- c. Locate the louver area in the walls of the enclosure such that air flows uniformly to the air intakes.
- d. If the unit is elevated to ensure the discharge is at the same level or above the top of the enclosure, it is acceptable to extend the louvered or slot area below the base of the units up to 0,6 m if needed to achieve the minimum gross louver area. To calculate air velocity through the louver, the useable louvered or slot area may extend beyond the ends of the unit, by 1,2 m maximum.

Calculate the louver velocity as follows:

$$\text{Louver Velocity} = \frac{\text{Total Unit Airflow (m}^3\text{/s)}}{\text{Louver Free Area (\%)} \times \text{Useable Louver Area (m}^2\text{)}} < 3 \text{ m/s}$$

Example: Model S3-D436 L in a Louvered Enclosure

The enclosure is 8 m long x 6 m wide x 3 m tall. The enclosure walls are equal in elevation to the unit discharge height. The louvers are 70% free area and 0,9 m from the air inlet of the tower. The louvers extend the full width of the enclosure (5 m) on both air intake ends and they extend 2,5 m vertically of the 3 m enclosure height.

Unit Airflow = 49,2 m³/s

Unit Length = 3,0 m

d max. = 1,2 m per side

Useable Louver Length = 1,2 + 3,0 + 1,2 = 5,4 m

(of total 6 m louver length)

3 m/s = Maximum Allowable Louver Velocity

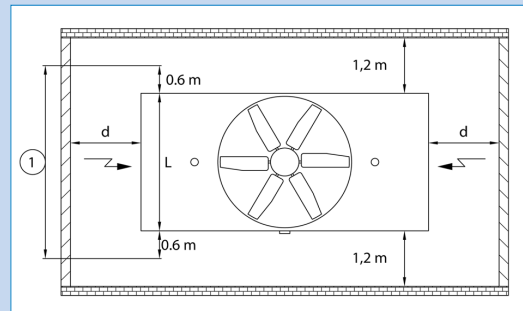

Figure 9: Unit with Two Air Inlets in Enclosure with Louvered Walls
1. Useable Louver Length

$$\text{Louver vel.} = \frac{\text{Louver Face Airflow (m}^3\text{/s)}}{\% \text{ Louver Free Area} \times \text{Useable Louver Area}}$$

$$\text{Louver vel.} = \frac{49,2 \text{ m}^3\text{/s} / 2 \text{ intake sides}}{70\% \times [(1,2+3,0+1,2) \times 2,5]}$$

$$\text{Louver vel.} = \frac{24,6 \text{ m}^3\text{/s}}{9,45 \text{ m}^2}$$

$$\text{Louver vel.} = 2,60 \text{ m/s}$$

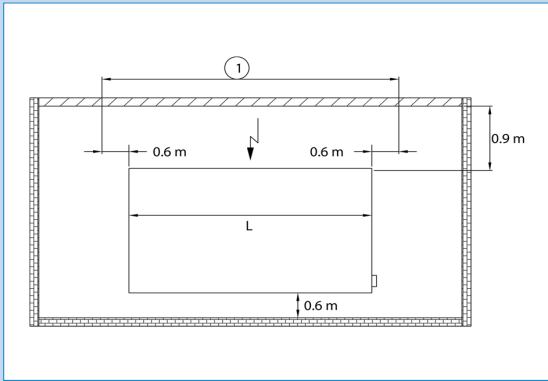

Figure 10: Unit with Single Air Inlet in Enclosure with Louvered Wall
1. Useable Louver Length

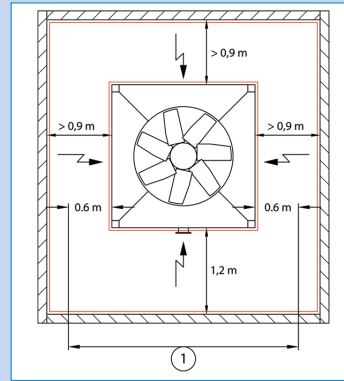

Figure 11: Unit with Four Air Inlets in Enclosure with Louvered Walls
1. Useable Louver Length

Therefore, louver sizing is sufficient because $2,6 \text{ m/s} < 3 \text{ m/s}$ maximum allowable. The same procedure as described above, can be followed in order to determine whether the layout meets the requirements for a louvered well installation.

7. Multi Unit Installation

- ◆ Multi unit installations adjacent to a building (wall) or in a well enclosure are subject to similar air velocities as those specified for individual units.
- ◆ An installation, consisting of several units, creates a “wall” of moist discharge air which could easily be swept into the air intakes due to prevailing wind. To minimize the potential of recirculation of the discharge air, the units should be situated with adequate spacing between air intakes. Therefore for units that are arranged with the air intakes facing each other, the distance between air intakes should follow this equation: $M = (2 \times d) + [(\text{number of cells per module}) \times 0,3 \text{ m}]$, where “d” is obtained from the appropriate model.
- ◆ Multi unit installations should be elevated a minimum of 0,6 m whenever possible to allow air equalisation under the cells, and minimize recirculation.
- ◆ When more than two units are installed indoor, it’s recommended to use individual ductworks.

8. Indoor Installation

Many indoor installations require the use of inlet and/or discharge ductwork. **Units installed with inlet ductwork must be ordered with solid-bottom panels.** Generally, intake ducts are used only on smaller units while the equipment room is used as a plenum for larger units. Discharge ductwork will normally be required to carry the saturated discharge air from the building. Both intake and discharge ductwork must have access doors to allow servicing of the fan assembly, drift eliminators, and water distribution system. All ductwork is supplied and installed by others and should be symmetrical and designed to provide even air distribution across the face of air intakes and discharge openings. Such ductwork may increase the external static pressure on the unit, requiring a larger fan motor to be installed. This external static pressure must be quantified (in Pa) to BAC to allow for suitable fan motor sizing.

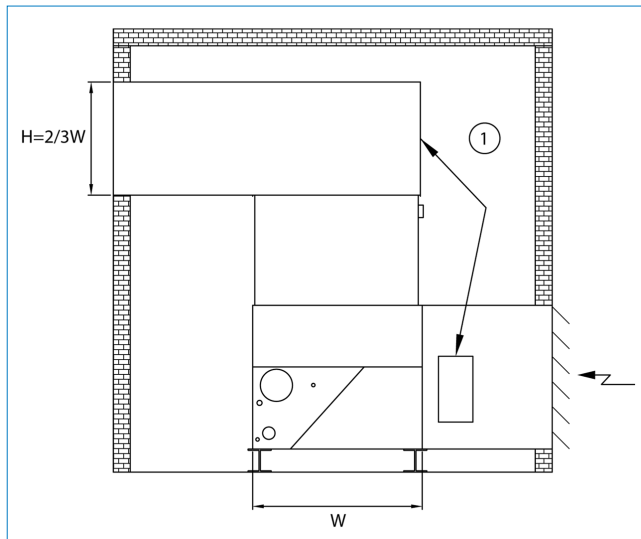

Figure 12: Ducted Unit Enclosure
1. Access Doors

The discharge opening must be positioned to prevent the introduction of discharge air into the fresh air intakes serving the unit or the ventilation systems of adjacent buildings.

Axial fan units are not generally suitable for indoor or ducted installations. In such situations, centrifugal fan units are recommended.

Ductwork Requirements

- ◆ Air velocities in the inlet duct should be kept below 4 m/s to hold static pressure losses to a minimum and ensure a uniform supply of air to all fans. In general the maximum allowable ESP on centrifugal fan units is 250 Pa. Consult your local BAC Baltimore Representative for any ESP greater than 250 Pa.
- ◆ Air velocities in the discharge duct(s) should not exceed 5 m/s to reduce friction losses in the duct, and more importantly, to ensure uniform air through the unit.
- ◆ Turns in inlet or discharge ducts should be avoided. Where turns must be used, velocities should be minimized in the vicinity of the turn. Turns in discharge ducting should be designed in accordance with the “2/3 rd rule” shown in Figure 12.
- ◆ Where individual fan sections are to be cycled for capacity control, each fan section must be ducted as a separate system on both inlet and discharge to avoid recirculation within the ductwork. All ductwork systems should be symmetrical to ensure that each fan section operates against the same ESP.
- ◆ Access doors must be provided in both the inlet and discharge ducts.
- ◆ When multi-units are located indoors with the room as a plenum, the installation must be operated as a single unit to avoid pulling air through an idle cell.

9. Dry Coolers and Dry Coolers with Adiabatic Pre-Cooling

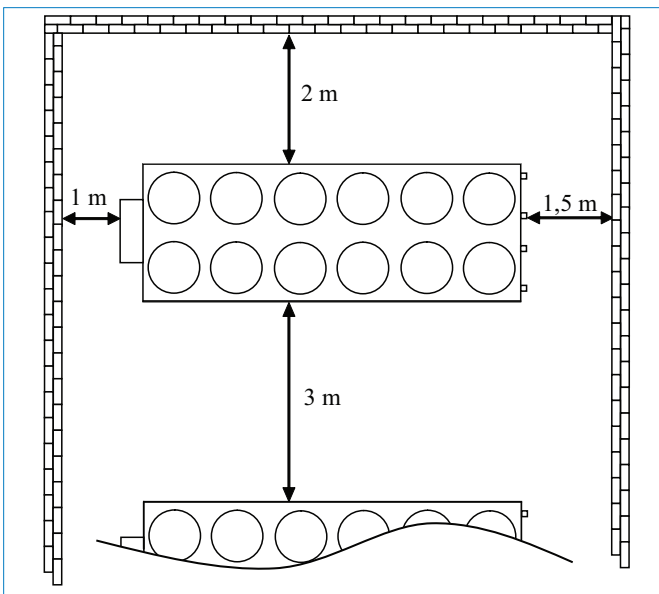

Figure 13: V-shaped Dry Cooler

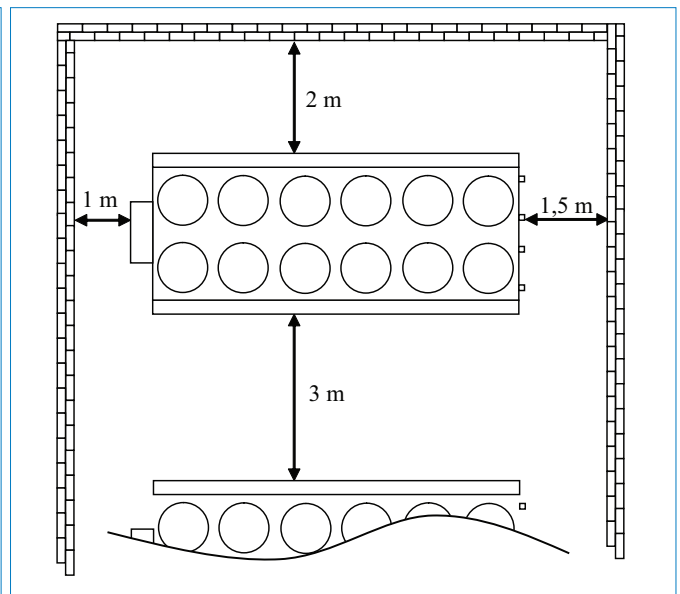

Figure 14: Dry Cooler with Adiabatic Pre-Cooling

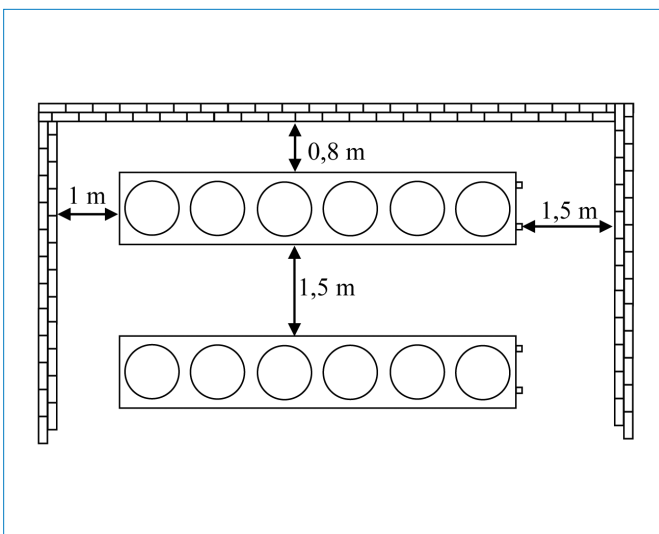

Figure 15: Horizontal Dry Cooler - single row fans

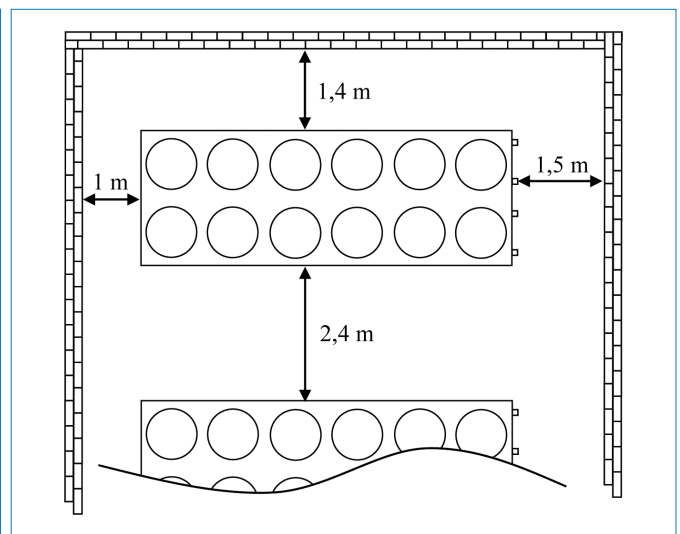

Figure 16: Horizontal Dry Cooler - double row fans