



**BALTIMORE
AIRCOIL COMPANY**



CXV-D Evaporative Condensers

RIGGING AND INSTALLATION INSTRUCTIONS





About Rigging and Installation

The BAC equipment should be rigged and installed as outlined in this bulletin.

These procedures should be thoroughly reviewed prior to the rigging and operation to acquaint all personnel with the procedures to be followed and to assure that all necessary equipment will be available at the jobsite.

Be sure to have a copy of the unit certified drawing available for reference. If you do not have a copy of this drawing or if you need additional information about this unit, contact the local BAC Balticare representative. His name and phone number can be found on the BAC website: www.BaltimoreAircoil.eu or www.BaltimoreAircoil.co.za. The model type and serial number of your equipment are indicated on the unit nameplate.

Recommended Maintenance and Monitoring Programme

Checks and Adjustments	Start-Up	Weekly	Monthly	Quarterly	Every 6 Months	Annually	Shutdown
Cold Water Basin and Basin Strainers	X			X			
Operating level and make-up	X		X				
Blow down	X		X				
Sump heater Package	X				X		
Belt tension	X		X				
Drive alignment	X					X	
Locking Collar	X						
Rotation of fan(s) and pump(s)	X						
Drive Train	X				X		
Gear Drive	X	X					
Variable Frequency Drive	X						
Motor voltage and current	X			X			
Unusual noise and/or vibration	X		X				

Inspections and Monitoring	Start-Up	Weekly	Monthly	Quarterly	Every 6 Months	Annually	Shutdown
General condition	X		X				
Heat transfer section and drift eliminators	X				X		
Combined Inlet Shields	X			X			
Water distribution	X				X		
Fan shaft & Axial Fan	X			X			
Fan Motor	X			X			
Spray Water Pump	X			X			
Electric Water Level Control Package (option)	X				X		
TAB test (dip slides)	X	X					
Circulating water quality	X		X				

Inspections and Monitoring	Start-Up	Weekly	Monthly	Quarterly	Every 6 Months	Annually	Shutdown
System overview	X					X	
Recordkeeping	as per event						

Lubrication	Start-Up	Weekly	Monthly	Quarterly	Every 6 Months	Annually	Shutdown
Fan shaft bearings	X			X			X
Motor bearings*	X				X		
Adjustable motor base	X				X		X
Gear Drive	X				X		

* only for motors with grease fittings with typical frame size > 200L (>30 kW)

Cleaning procedures	Start-Up	Weekly	Monthly	Quarterly	Every 6 Months	Annually	Shutdown
Mechanical cleaning	X					X	X
Disinfection**	(X)					(X)	(X)
Drain Basin							X

** depends on applied code of practice

Notes

1. Water Treatment and auxiliary equipment integrated in the cooling system may require additions to the table above. Contact suppliers for recommended actions and their required frequency.
2. Recommended service intervals are for typical installations. Different environmental conditions may dictate more frequent servicing.
3. When operating in ambient temperatures below freezing, the unit should be inspected more frequently (see Cold Weather Operations in the appropriate Operating and Maintenance Instructions).
4. For units with Belt Drive, tension on new belts must be readjusted after the first 24 hours of operation and monthly thereafter.



Table of Contents

RIGGING AND INSTALLATION INSTRUCTIONS

1	General Information	5
	About Engineering and Application Practices	5
	Shipping	5
	Inspection Before Rigging	5
	Unit Weights	6
	Anchoring	7
	Leveling	7
	Connecting Pipework	7
	Coil Connections	7
	Purge Requirements	8
	Freeze Protection	9
	Bleed Line Installation	9
	Safety Precautions	9
	Non-walking Surfaces	10
	Modifications by others	10
	Warranty	11
2	Rigging	12
	General Notes	12
	Rigging Information	13
	Rigging Method for Coil Section	14
	Rigging Method for Plenum Section	14
	Rigging Method for Lower Section	15
	Rigging Method for External Motor	15
3	Section Assembly	16
	Rigging Lower Section	16
	Rigging Plenum Section	17
	Rigging Coil Section	20
	Rigging Multiple Cell Installations	24
4	Optional Accessories Assembly	25
	General	25
	Internal Service Platform	25
	Clean Out Port	26
5	Inspection Prior to Start-up	27
	General	27
6	Further Assistance & Information	28
	Balticare	28
	More Information	28



CXV-D GENERAL INFORMATION

About Engineering and Application Practices

This bulletin only refers to the assembly of the unit. To ensure a proper operation, a correct integration of the unit in the overall installation is mandatory. For good engineering and application practices on layout, levelling, connecting pipework, etc., please refer to our website:

<http://www.baltimoreaircoil.co.za/knowledge-center/application-information>.

Shipping

BAC cooling equipment is factory assembled to assure uniform quality and minimum field assembly. The models ship in 4 sections per cell (one lower and three upper) to ease rigging and minimize freight costs. The 3 upper sections consist of 1 plenum section and 2 coil sections.

If sound attenuation is included in the order, intake sound attenuator sections are always factory-mounted on the lower section and ship as one piece. The discharge sound attenuator section(s) is (are) shipped loose for rigging on site and ship separately.

For the dimensions and weights of a specific unit or section, refer to the certified drawing.



Caution

DO NOT COVER UNITS WITH PVC ELIMINATORS OR FILL WITH A PLASTIC TARPAULIN. TEMPERATURE INCREASE DUE TO SUN RADIATION COULD DEFORM THE FILL OR ELIMINATORS.

Inspection Before Rigging

When the unit is delivered to the jobsite, it should be checked thoroughly to ensure all required items have been received and are free of any shipping damage prior to signing the bill of lading.

The following parts should be inspected:

- Sheaves and belts
- Gearbox
- Bearings
- Bearing supports
- Fan motor(s)
- Fan(s) and fan shaft(s)
- Wet Deck Surface with integral drift eliminators
- Coils
- Water distribution system
- Strainers



- Float valve assembly
- Spray pump(s)
- Eliminators
- Combined Inlet Shields
- Interior / exterior surfaces
- Intake Hood Assembly (if applicable)
- Miscellaneous items

An envelope with check-list is stored in a wooden no nail crate or a plastic container which is placed in the lower section. For safety reasons, access doors / panels may be sealed with bolts. The following table specifies which wrench is required to open them.

Wrench to open access door
17 mm

Required wrenches to open access door

The wooden no nail crate / plastic container also contains miscellaneous parts such as gasket, hardware and accessory items.

At temperatures below -10°C the butyl sealer tape might loose it's flexibility. We recommend to store the sealer tape in a heated room before using it during rigging at freezing temperatures.



Caution

BE SURE TO REMOVE ALL MISCELLANEOUS ITEMS FROM THE PAN BEFORE THE UNIT IS ASSEMBLED.

The wooden box with the hardware is placed inside the unit or in the lower section of the unit. This box is fixed with straps to the internal walkway of the unit.

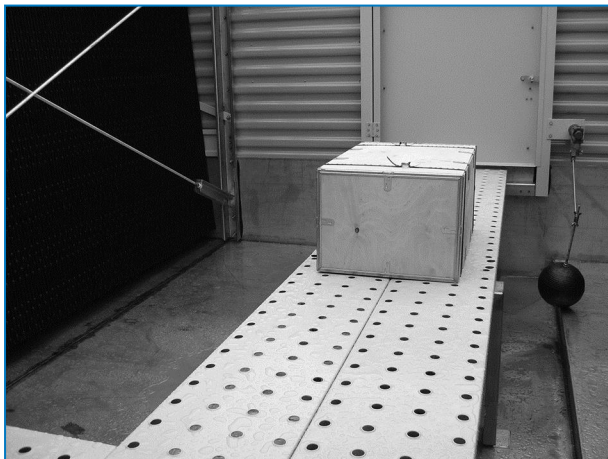

Hardware Location

Unit Weights

Before rigging any BAC equipment, the weight of each section should be verified on the unit certified drawing.



These weights are **approximate** and should be confirmed by weighing **before lifting** when available hoisting capacity provides little margin for safety.



Caution

BEFORE AN ACTUAL LIFT IS UNDERTAKEN, ENSURE NO WATER, SNOW, ICE OR DEBRIS HAS COLLECTED IN THE SUMP OR ELSEWHERE IN THE UNIT. SUCH ACCUMULATIONS WILL ADD SUBSTANTIALLY TO THE EQUIPMENT'S LIFTING WEIGHT.

In the event of extended lifts or where hazards exist, the lifting devices should be used in conjunction with safety slings placed under the unit.

Anchoring

The unit must be properly anchored in place.

Refer to the suggested support details on the certified drawing for locations of the mounting holes. Anchor bolts must be provided by others.

Holes suitable for 20 mm bolts are provided in the bottom flange of the lower section for bolting the unit to the support beams.

Leveling

The unit must be level for proper operation and ease of piping.

Support beams must also be level as shims should not be used between pan and support beams to level the unit.

Connecting Pipework

All piping external to BAC cooling equipment must be supported separately.

In case the equipment is installed on vibration rails or springs, the piping must contain compensators to eliminate vibrations carried through the external pipework.

Suction pipe sizing should be done according to good practice, which may for larger flows require larger pipe diameters than the outlet connection. In such cases adapter pieces need to be installed.

Coil Connections

Hot dip galvanized and stainless steel coils of BAC condensers are filled with a low pressure inert gas at the factory before shipping, to ensure an optimal internal corrosion protection. It is recommended to check the overpressure every six months (connect a manometer to the valve).

On site, the pressure needs to be released from the coil. Remove the plug first before opening the pressure relieve valve.

Next the connections need to be cut at 1cm from the end. Make sure to protect the unit against sparks from the cutting process with a suitable material.

In case of threaded connections, clean up the thread prior to connecting it to the pipework.

Non-threaded connections must be bevelled on site before they can be welded.



Upper Coil Connection with pressure release valve on condensers.

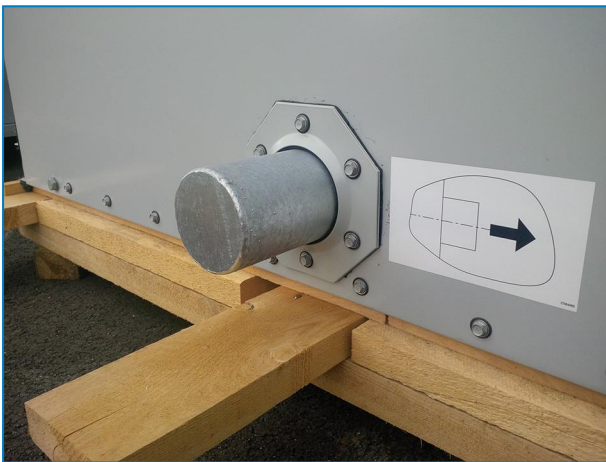

Lower closed-off coil connection on evaporative condensers.



Caution

ONCE THE COIL IS NO LONGER PROTECTED BY THE INERT GAS, PROPER ACTIONS AGAINST CORROSION MUST BE TAKEN ON SITE.

Purge Requirements

The installer of BAC condensers must ensure proper air purging of the system prior to operation. Entrained air can obstruct free drainage of refrigerant and reduce condensing capacity, resulting in higher operating pressures than designed.

To verify absence of non condensables in the refrigeration system, follow the instructions in the BAC Application Handbook – EU Edition (<https://www.baltimoreaircoil.co.za/downloads/pdf-Application-Handbook-EU-Edition>), Section "Condenser Engineering Guidelines".

All connections (installed by others) must be leak free and tested accordingly.

Freeze Protection

These products must be protected against damage and/or reduced effectiveness due to possible freeze-up by mechanical and operational methods. Please refer to the BAC Product & Application Handbook or contact your local BAC Balticare representative for recommended protection alternatives.

Bleed Line Installation

On units operating with a remote sump tank, install a bleed line with valve between the system circulating pump discharge riser and a convenient drain. Locate the bleed line in a portion of the riser piping that drains when the pump is off.

Evaporative condensers that are furnished with a factory installed circulating pump include a bleed line with valve. The bleed valve should always be open when the unit is in operation, unless the bleed rate is automatically controlled by a water treatment system.

Safety Precautions

All electrical, mechanical and rotating machinery constitutes a potential hazard, particularly for those not familiar with its design, construction and operation. Accordingly, adequate safeguards (including use of protective enclosures where necessary) should be taken with this equipment both to safeguard the public (including minors) from injury and to prevent damage to the equipment, its associated system and the premises.

If there is doubt about safe and proper rigging, installation, operation or maintenance procedures, contact the equipment manufacturer or his representative for advice.

When working on operating equipment, be aware that some parts may have an elevated temperature. Any operations on elevated level have to be executed with extra care to prevent accidents.

AUTHORIZED PERSONNEL

The operation, maintenance and repair of this equipment should be undertaken only by personnel authorized and qualified to do so. All such personnel should be thoroughly familiar with the equipment, the associated systems and controls and the procedures set forth in this and other relevant manuals. Proper care, personal protective equipment, procedures and tools must be used in handling, lifting, installing, operating, maintaining and repairing this equipment to prevent personal injury and/or property damage. Personnel must use personal protective equipment where necessary (gloves, ear plugs, etc...)

MECHANICAL SAFETY

Mechanical safety of the equipment is in accordance with the requirements of the EU machinery directive.

Depending upon site conditions it also may be necessary to install items such as bottom screens, ladders, safety cages, stairways, access platforms, handrails and toe boards for the safety and convenience of the authorized service and maintenance personnel.

At no time this equipment should be operated without all fan screens, access panels and access doors in place. When the equipment is operated with a variable fan speed control device, steps must be taken to avoid operating at or near to the fan's «critical speed».

For more information consult your local BAC Balticare representative.

ELECTRICAL SAFETY

Each fan and pump motor associated with this equipment should be installed with a lockable disconnect switch located within sight of the equipment. No service work should be performed on or near the fans, motor, drives or inside the equipment unless fan and pump motors, heaters etc. are electrically isolated.

Each fan associated with this equipment should be installed with a lockable disconnect switch located within sight of the equipment. No service work should be performed on or near the fans unless motors are electrically isolated.

LIFTING



Caution

FAILURE TO USE DESIGNATED LIFTING POINTS CAN RESULT IN A DROPPED LOAD CAUSING SEVERE INJURY, DEATH AND/OR PROPERTY DAMAGE. LIFTS MUST BE PERFORMED BY QUALIFIED RIGGERS FOLLOWING BAC PUBLISHED RIGGING INSTRUCTIONS AND GENERALLY ACCEPTED LIFTING PRACTICES. THE USE OF SUPPLEMENTAL SAFETY SLINGS MAY ALSO BE REQUIRED IF THE LIFT CIRCUMSTANCES WARRANT ITS USE, AS DETERMINED BY THE RIGGING CONTRACTOR.

LOCATION

All cooling equipment should be located as far away as possible from occupied areas, open windows or air intakes to buildings.



Caution

EACH UNIT SHOULD BE LOCATED AND POSITIONED TO PREVENT THE INTRODUCTION OF DISCHARGE AIR INTO THE VENTILATION SYSTEMS OF THE BUILDING ON WHICH THE UNIT IS LOCATED OR THOSE OF ADJACENT BUILDINGS.



For detailed recommendations on BAC equipment layout, please see the BAC Application Handbook EU-Edition, the BAC website: www.baltimoreaircoil.eu or contact your local BAC-Balticare Representative.

LOCAL REGULATIONS

Installation and operation of cooling equipment may be subject to local regulations, such as establishment of risk analysis. Ensure regulatory requirements are consistently met.

Non-walking Surfaces

Access to and maintenance of any component needs to be performed in accordance with all local applicable laws and regulations. If the proper and required access means are not present, temporary structures need to be foreseen. Under no circumstance can one use parts of the unit, that are not designed as an access mean, unless measures can be taken to mitigate any risks that might occur from doing so.

Modifications by others

Whenever modifications or changes are made by others to the BAC equipment without written permission of BAC, the party who has done the modification becomes responsible for all consequences of this change and BAC declines all liability for the product.

Warranty

BAC will guarantee all products to be free from manufactured defects in materials and workmanship for a period of 12 months from the date of shipment. In the event of any such defect, BAC will repair or provide a replacement. For more details, please refer to the Limitation of Warranties applicable to and in effect at the time of the sale/purchase of these products. You can find these terms and conditions on the reverse side of your order acknowledgement form and your invoice.



2

CXV-D RIGGING

General Notes

1. Unless unit ships fully assembled, unit must be rigged one section at a time.
2. If the delivery consists of separate sections, do not assemble before lifting, as the lifting devices provided are not designed to support the weight of the entire assembly.
3. Spreader bars of the full width of the section must be used between the lifting cables to prevent damage to the section.
4. For extended lifts or where hazards exist, it is recommended to use the lifting devices in conjunction with safety slings placed under the unit.
5. The proper rigging sequence for units is to lift the lower section into place, apply gasket on the flanges of the lower section (1) where the upper section will be located and then lift the upper plenum section (2) into place. Apply D-sealer to both vertical sides of the plenum section where the coil sections (3) will be located. Lift the coil sections into place using the male and female rigging guides into both plenum and coil sections. (For details see "Section Assembly".)
6. If the (pump) piping from coil products is split for transport reasons, the piping must be assembled on site by means of a flexible connection (typically a rubber sleeve or coupling).
7. Units equipped with intake sound attenuation are installed as an integral part of the unit. The use of the alternative lifting device location requires the removal of the intake sound attenuation from the unit section.
8. Lifting devices have been provided on all sections. The tables below give the preferred method for rigging each section of a unit.

Rigging Information

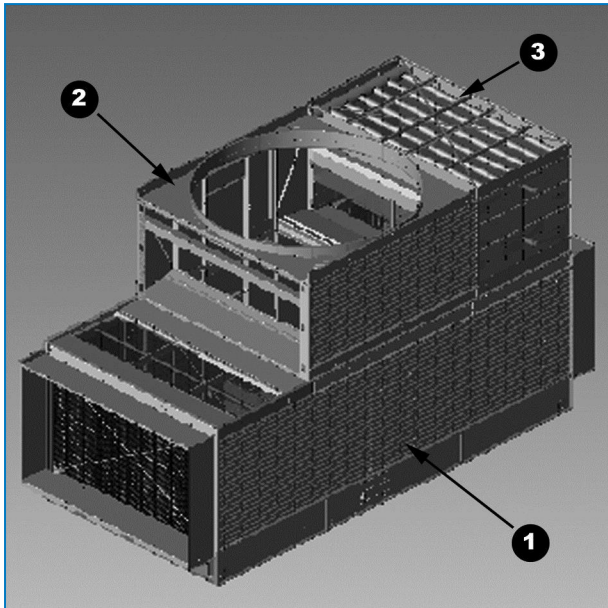

Unit Sections

1. Lower Section
2. Plenum Section
3. Coil Section

Model Number	Model	N° Sections	Rigging Method	Minimum "H" (mm)	Minimum "W" (mm)
CXV-D645 thru D792	Lower Section	1	C	6100	3700
	Plenum Section	1	B	5500	3700
	Coil Sections	2	A	4300	3700
CXV-D791 thru D944	Lower Section	1	C	6100	4300
	Plenum Section	1	B	5500	4300
	Coil Sections	2	A	4300	4300

Rigging Method

Rigging Method for Coil Section

RIGGING METHOD A

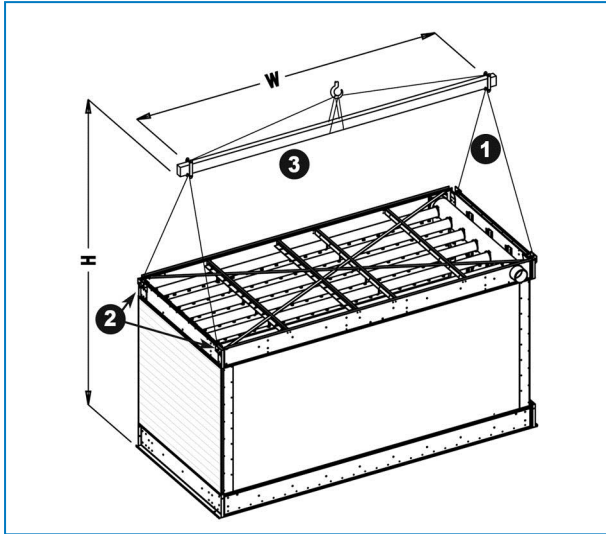

Coil Section

1. Lifting Cable
2. Lifting Ear/Device
3. Spreader Bar

Rigging Method for Plenum Section

RIGGING METHOD B

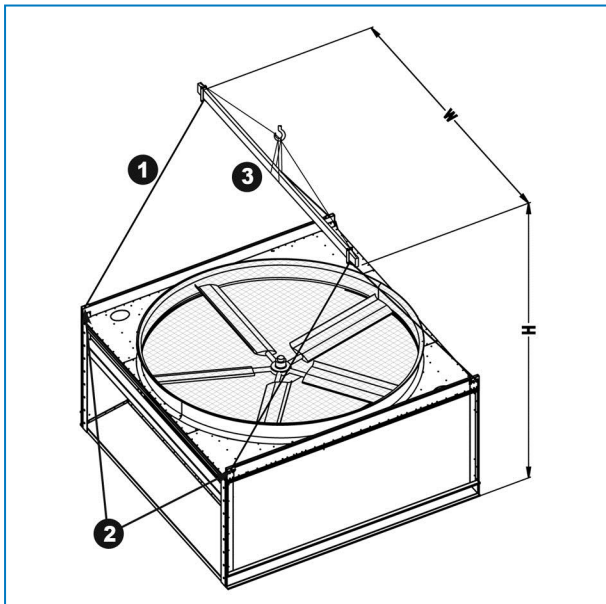

Plenum Section

1. Lifting Cable
2. Lifting Ear/Device
3. Spreader Bar

Rigging Method for Lower Section



RIGGING METHOD C

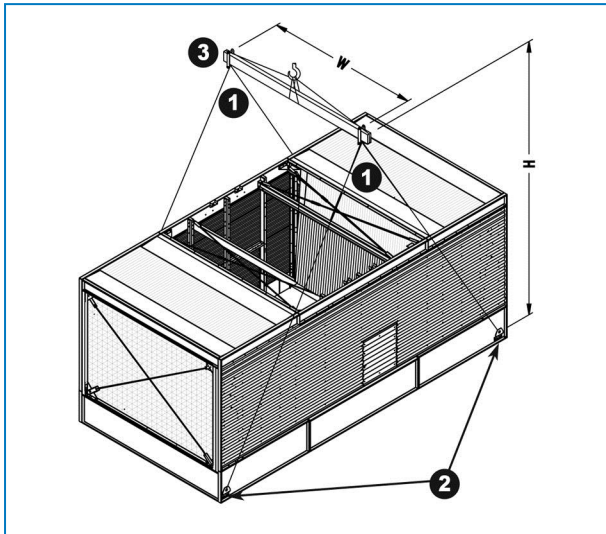

Lower Section

1. Lifting Cable
2. Lifting Ear/Device
3. Spreader Bar

Rigging Method for External Motor

For units with external motor see separate instructions in appendix 1.

3

CXV-D SECTION ASSEMBLY

Rigging Lower Section

First, position the lower section on the unit supports and bolt in place. Wipe down the upper flanges to remove dust, dirt or moisture that may have accumulated during shipment and storage. Install foam sealer supplied with the unit, as illustrated in the figures below on the mating flanges of the lower section.

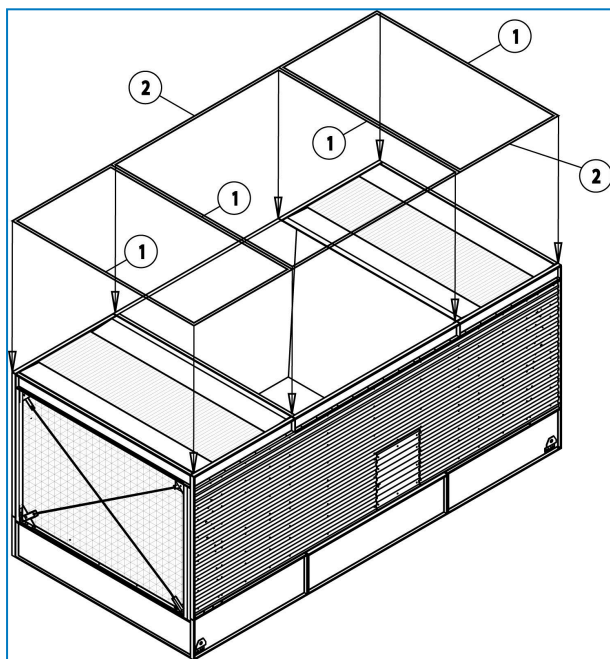

Lower Section

1. Foam Sealer transversal direction
2. Foam Sealer longitudinal direction

Overlap foam sealer tape at junctions of longitudinal and transversal flanges. Use one single piece of foam sealer per flange (overlap joints if not possible).

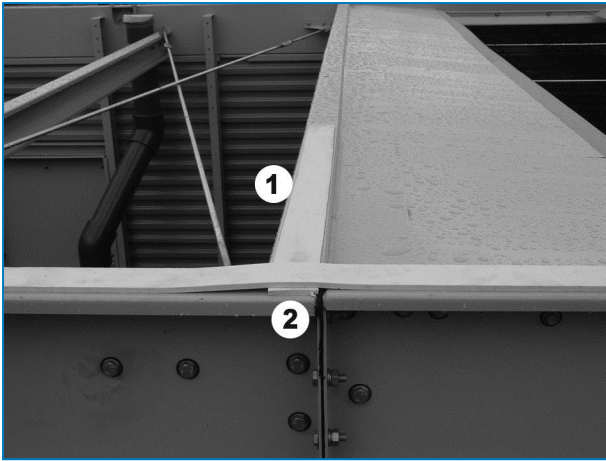

Detail – Overlap Foam Sealer Tape

1. Apply Foam Sealer Tape in transversal direction of the unit.
2. Overlap Foam Sealer ① with Foam Sealer ② in longitudinal direction of unit.

Rigging Plenum Section

The units are designed to position the plenum section within ± 3 mm both transversely and longitudinally. On the lower section are 4 locations to position the plenum section on the typical rigging guide/bracket for a 3.6 m wide cell and 8 locations for a 4.2 m wide cell.



Caution

WHEN LOWERING A SECTION, ENSURE NOTHING CAN BE TRAPPED BETWEEN THE UPPER AND LOWER FLANGES.

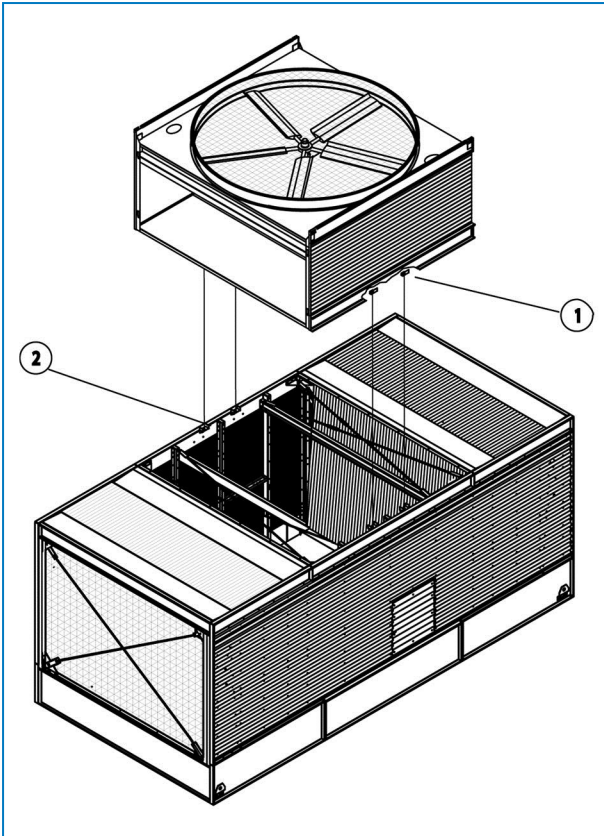

Rigging Plenum Section on Lower Section

1. Rigging Guides/Bracket of Plenum Section
2. Rigging Guides/Bracket of Lower Section



Inside View Plenum Section

1. Rigging Guide/Bracket of Plenum section

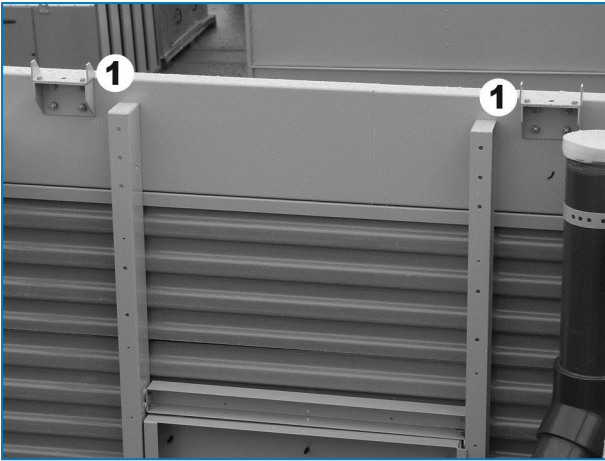

Inside View Lower Section

1. Rigging Guide/Bracket of Lower Section

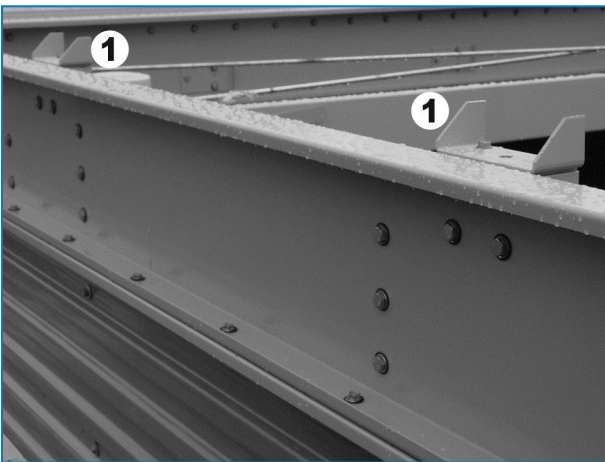

Outside View Lower Section

1. Rigging Guide/Bracket of Lower Section



Plenum Section installed on Lower section

1. Rigging Guides/Brackets
2. Bolt & Nut

Secure the plenum section to the lower section utilising typical bolting technique as shown in figure below, using the internal rigging guide brackets with bolt holes.

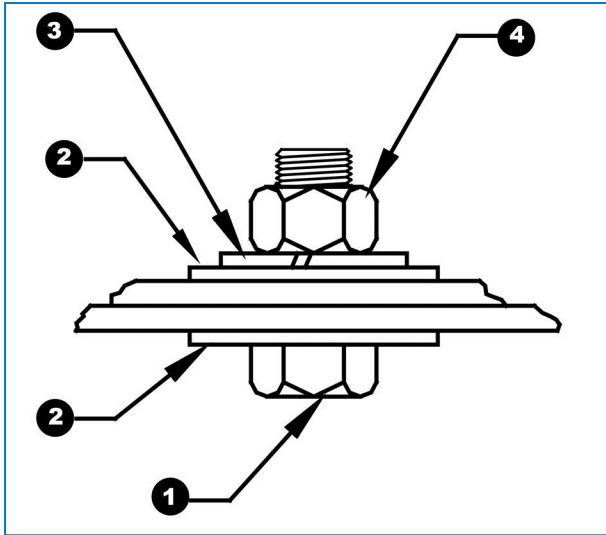

Typical Bolting Technique

- 1. Bolt
- 2. Flatwasher
- 3. Lockwasher
- 4. Nut

Rigging Coil Section

Prior to rigging the coil section, install "D"-sealer that will accommodate a greater variance, along vertical flange between the coil and plenum sections.

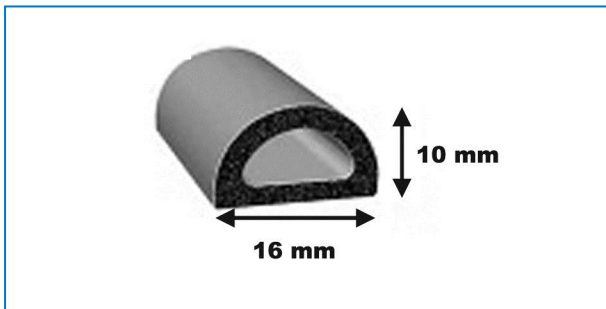

D-Sealer Tape

Apply D-sealer tape next to the female rigging guides on the plenum section over the total vertical flange length, at the four corner flanges. Make sure the D-sealer tape is in one piece. Rigging guides for the coil section are integrated into both the plenum and coil sections.

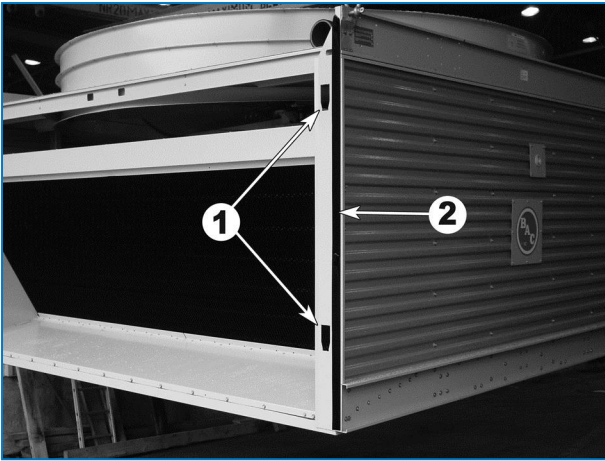

Female Rigging Guides on Plenum Section

1. Female rigging guides.
2. D-sealer applied over the total vertical flange length.

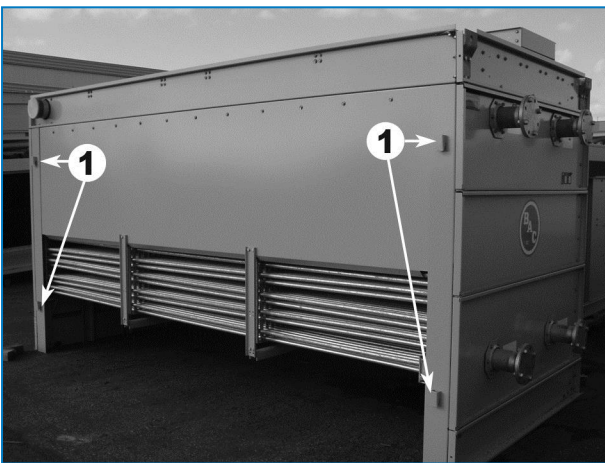

Male Rigging Guides on Coil Section

1. Male Rigging Guides

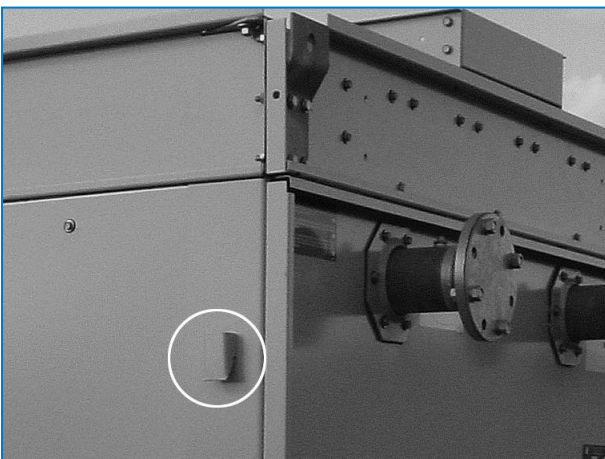

Detail Male Rigging Guides on Coil Section

Align the coil section to the plenum section by lining up the male and female guides until the top of the male guide is at the same level as the top of the female guide. Move the coil section closer to the plenum section until the guides have the possibility to click together. Lower the coil section into the final position. The rigging guides will draw the coil section tightly against the plenum section. Secure the coil section to lower section in the length and width direction, using the supplied hardware.

Both pump pipings must be joined with a rubber sleeve and hose clamps. Follow the sequence as shown on the pictures below.

Make joint 1 and joint 2 with sleeve with hose clamp.



Sleeve with Hose Clamps

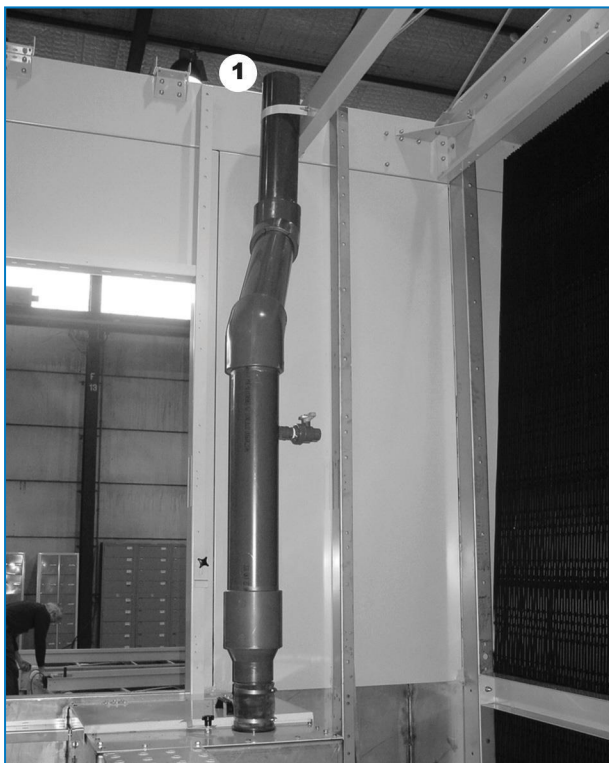

Pump Piping Lower Section



Pump Piping Plenum Section Inside



Pump Piping Connection on Plenum Section Outside



Pump Piping Connection on Coil Section

Rigging Multiple Cell Installations



Caution

FOR MULTIPLE CELL EXECUTIONS, ALL ACCESS DOOR SEALING BOLTS NEED TO BE REMOVED BEFORE RIGGING

1. For multiple cell installations, position the second lower section next to the first section. This is possible when you use a narrow lifting shackle. Using a narrow shackle will allow the pin shackle to be removed from between the units after final positioning.

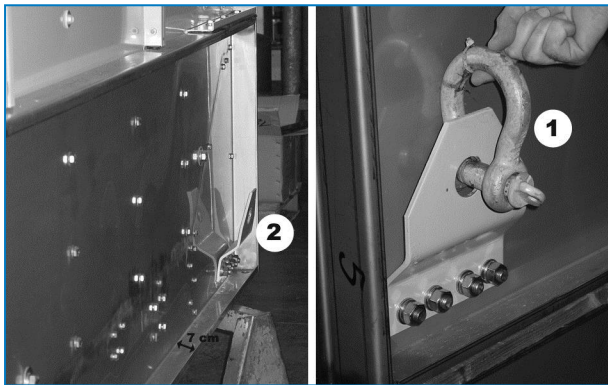

Multiple Cell Installation

2. Remove lifting ear of first lower section before positioning the second lower section.
3. Sufficient space (min. 120 mm) is available to position the units next to each other.
4. The rigging of the second plenum section and the two coil sections is the same as on the first cell.

4

CXV-D OPTIONAL ACCESSORIES ASSEMBLY

General

1. All required installation instructions for optional accessories are stored in the wooden no nail crate / plastic container which is placed in the lower section. See "Inspection Before Rigging" on page 5- picture "Hardware Location".
2. Optional intake and/or discharge accessories such as positive closure dampers and discharge sound attenuators can be fitted.
3. The platform, ladder and railing is packed on a separate skid. The assembly hardware is packed in a plastic container and strapped to the platform, ladder or railing itself.



Hardware Location for platform, ladder & railing

Internal Service Platform

Remove the two shipping braces to be able to fix the remaining grids in the plenum section.

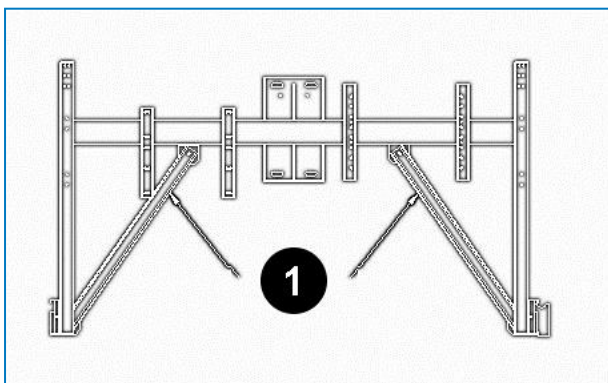

Shipping Braces

Shipping braces are required for shipping only. Braces can be removed if they interfere with platform handrails or obstruct the working area. If left in place, they will have no effect on equipment performance.

Clean Out Port

Due to transport width limits, the cover flanges of the clean out port are mounted with flanges towards the inside (1). On site, the cover can be placed with flanges to the outside for easy access to hardware (2).

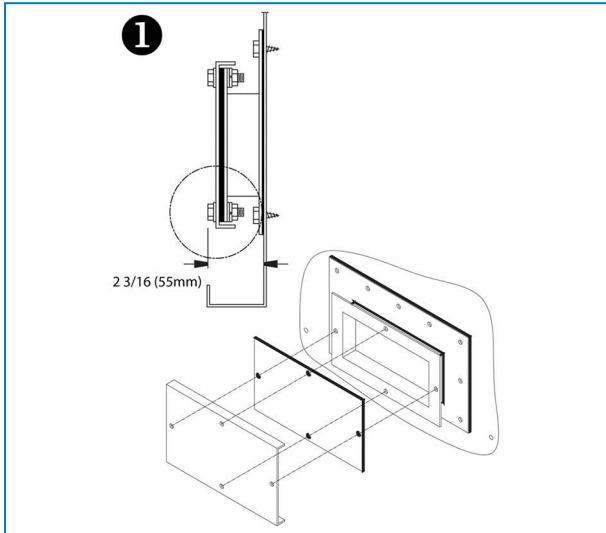

Clean out port cover mounted for transport

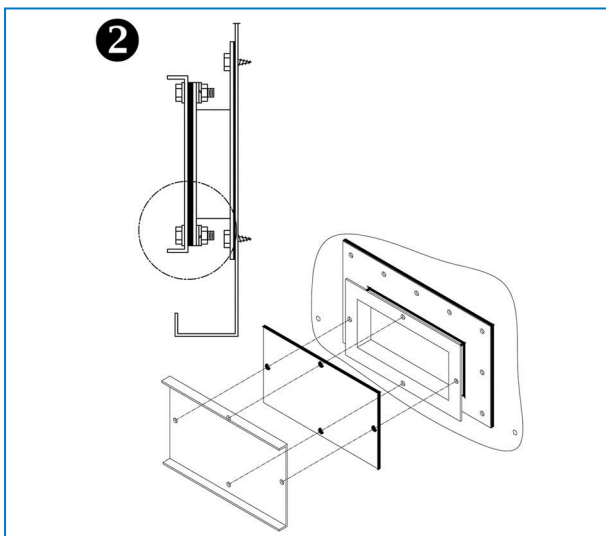

Final installation of clean out port cover



CXV-D

INSPECTION PRIOR TO START-UP

General

Prior to start-up, the following services, which are described in detail in the Operating and Maintenance Manual (see Table "Recommended Maintenance and Monitoring Programme" on page 2) must be performed. Proper start-up procedures and scheduled periodic maintenance will prolong the life of the equipment and ensure trouble-free performance for which the unit is designed.

Balticare

BAC has established a specialized independent total care company called Balticare. The BAC Balticare offering involves all elements required to ensure a safe and efficient operation of your evaporative cooling products. From a full range of risk assessment to selective water treatment, training, testing, record keeping and annual system overview.

For more details, contact your local BAC representative for further information and specific assistance www.BaltimoreAircoil.co.za.

More Information

REFERENCE LITERATURE

- Eurovent 9-5 (6) Recommended Code of Practice to keep your Cooling System efficient and safe. Eurovent/Cecomaf, 2002, 30p.
- Guide des Bonnes Pratiques, Legionella et Tours Aéroréfrigérantes. Ministères de l'Emploi et de la Solidarité, Ministère de l'Economie des Finances et de l'Industrie, Ministère de l'Environnement, Juin 2001, 54p.
- Voorkom Legionellose. Ministerie van de Vlaamse Gemeenschap. December 2002, 77p.
- Legionnaires' Disease. The Control of Legionella Bacteria in Water Systems. Health & Safety Commission. 2000, 62p.
- Hygienische Anforderungen an raumluftechnische Anlagen. VDI 6022.

INTERESTING WEB SITES

- www.BaltimoreAircoil.co.za
- www.BaltimoreAircoil.eu
- www.Balticare.com
- www.eurovent-certification.com
- www.ewgli.org
- www.ashrae.org
- www.uniclima.org
- www.aicvf.org
- www.hse.gov.uk



A series of horizontal dotted lines for writing, spanning the width of the page.



A series of horizontal dotted lines spanning the width of the page, providing a template for writing or drawing.





A series of horizontal dotted lines for writing.



A series of horizontal dotted lines spanning the width of the page, providing a template for writing or drawing.





A series of horizontal dotted lines for writing.

COOLING TOWERS

CLOSED CIRCUIT COOLING TOWERS

ICE THERMAL STORAGE

EVAPORATIVE CONDENSERS

HYBRID PRODUCTS

PARTS & SERVICES



www.BaltimoreAircoil.co.za

info@BaltimoreAircoil.co.za

Please refer to our website for local contact details.

PO Box 32088 - 7808 Ottery, Cape Province, South Africa

© Baltimore Aircoil International nv